

GSV

Gas Solenoid Valve

Installation and Maintenance Instructions



In this procedure document we have endeavoured to make the information as accurate as possible.

We cannot accept any responsibility should it be found that in any respect the information is inaccurate or incomplete or becomes so as a result of further developments or otherwise.

INTRODUCTION

The Gold Seal GSV solenoid valves are widely used in gas distribution to provide isolation and emergency shut-off.

The valves can be used on various hydrocarbon gases including natural gas, methane, and liquid petroleum gas.

OPERATION

The GSV solenoid valves will normally be in the closed position, but when energised will open quickly and a blue indicator light will be lit on the terminal box attached to the coil.

There are G¹/₄ holes on both sides of the valve body and at the bottom (¹/₂" to 2" size only). These can be used for various applications but notably a CPI (closed position indicator) or gas proving system.

TECHNICAL SPECIFICATION

Opening time:		< 1 second
Closing time:		< 1 second
Max. operating frequency:		20 time per minute
Maximum working pressure:	½" to 1"	360 mbar
	1¼" to 2"	200 mbar
	DN65 to DN100	200 mbar
Integral filter:		
Protection level:		IP54
Working temperature:		-15 to 60 °C
Coil temperature:		65 °C
Body connections - threaded:	½" to 2" Body	BS EN 10226
	connections - flanged PN8:	DN65
flanged PN16:	DN80 to DN100	BS EN 1092
Seal material:		NBR polymer
Body material:		Aluminium alloy
Spring material:		AISI 302 stainless steel

ELECTRICAL SPECIFICATION

Voltage:	230 V ac & 110 V ac
Rating:	50/60 Hz
Coil Level F:	360° rotation
Suitable for:	Permanent excitation

STANDARDS

According to European Standards:	90/396/EEC
According to standard:	73/23/EEC
	89/336/EEC
	EN 161

DIMENSIONS - 1/2" to 2" SIZES

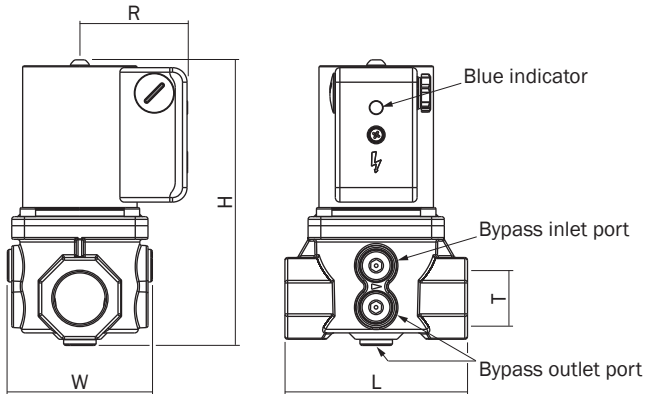

Code	T	L	W	H	R	230V AC Power - W
GSV15	Rp1/2	72	71	115	55	15
GSV20	Rp3/4	92	76	156	59	22
GSV25	Rp1	100	80	158	59	22
GSV32	Rp1 1/4	149	115	216	71	42
GSV40	Rp1 1/2	149	115	216	71	42
GSV50	Rp2	170	142	230	76	50

CAPACITY

The capacity in m³/hr at ΔP = 2.5 mbar.

Code	Size	m ³ /hr
GSV15	1/2"	6.4
GSV20	3/4"	14.8
GSV25	1"	16.7
GSV32	1 1/4"	38.5
GSV40	1 1/2"	47.1
GSV50	2"	66.7

PRESSURE DROP CHART - 1/2' to 2" SIZES

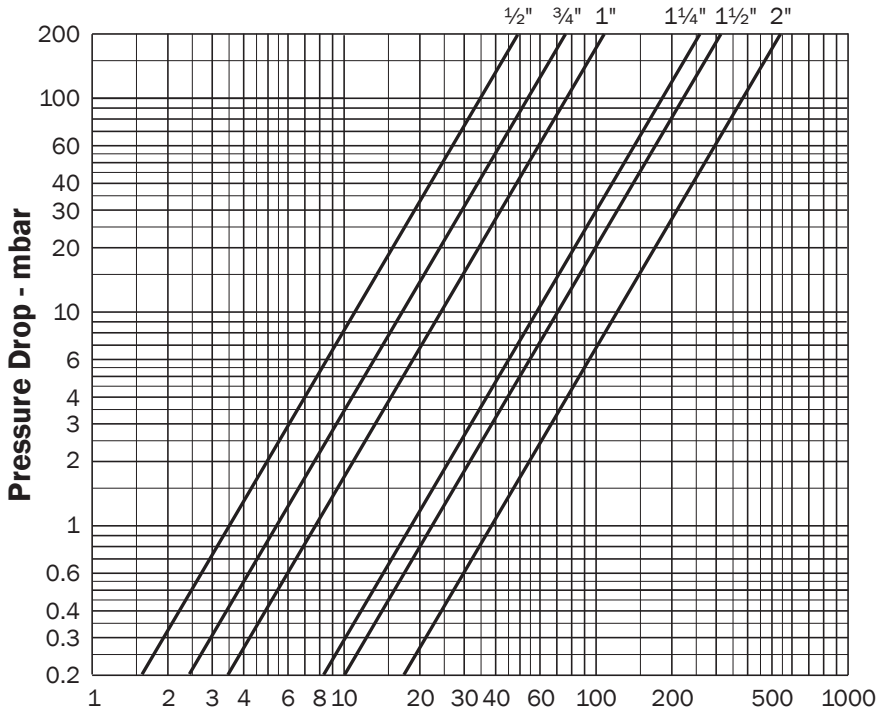

Based on +15°C, 1013 mbar, dry **Air Flow - Nm³/h**

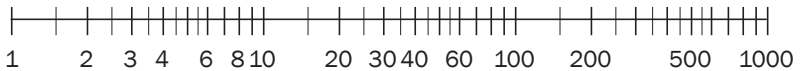

Based on f = 1.24 **Natural Gas Flow - Nm³/h**

$$dv = \frac{\text{Gas density}}{\text{Air density}}$$

$$f = \sqrt{\frac{\text{Relative density of air}}{\text{Relative density of gas}}}$$

Gas	Density kg/m ³	dv density ratio	f correction factor
Air	1.29	1.00	1.00
Natural gas	0.84	0.65	1.24
Liquid gas	2.19	1.70	0.77

DIMENSIONS - DN65 to DN100 SIZES

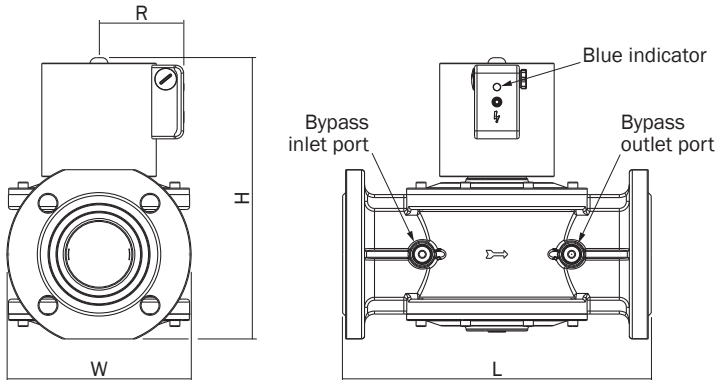

Code	L	W	H	R	230V AC Power - W
GSVF65	310	185	283	85	75
GSVF80	310	200	292	85	75
GSVF100	350	250	383	130	150

CAPACITY

The capacity in m³/hr at $\Delta P = 2.5$ mbar.

Code	Size	m ³ /hr
GSVF65	65	79
GSVF80	80	90
GSVF100	100	190

PRESSURE DROP CHART - DN65 to DN100 SIZES

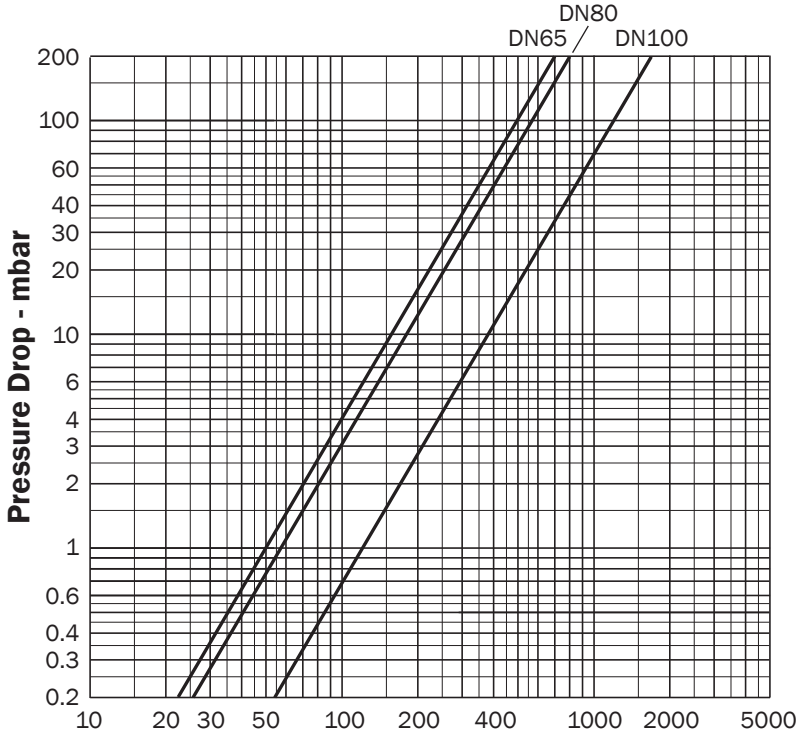

Based on +15°C, 1013 mbar, dry **Air Flow - Nm³/h**

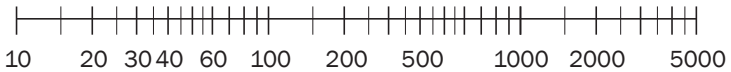

Based on $f = 1.24$ **Natural Gas Flow - Nm³/h**

$$dv = \frac{\text{Gas density}}{\text{Air density}}$$

$$f = \sqrt{\frac{\text{Relative density of air}}{\text{Relative density of gas}}}$$

Gas	Density kg/m ³	dv density ratio	f correction factor
Air	1.29	1.00	1.00
Natural gas	0.84	0.65	1.24
Liquid gas	2.19	1.70	0.77

GENERAL INSTALLATION RECOMMENDATIONS

- The GSV gas solenoid valve should be mounted directly in a vertical pipeline or in a horizontal pipeline with the coil uppermost.
- Check that the site conditions comply with the technical specification of the valve.
- The flow direction arrow on the valve body must match the direction of flow.
- Thoroughly purge the pipeline before installing the valve to prevent debris entering the valve and damaging the diaphragm and causing premature failure.
- A gas filter should be installed upstream of the valve to prevent the ingress of debris and prolong the interval between services and the life of the valve.
- **IMPORTANT:** the valve is not explosion proof.
- If installed outdoors or in a harsh environment the valve should be protected accordingly.
- If recommended install a bypass around the gas solenoid valve to aid isolation and future maintenance
- If the valve fails to open or close check that the power supply is connected correctly and turned on. Also check the pressure within the system is within the technical specification of the valve.
- If not installed on the valve, the coil should be stored indoors between 0 to 40 °C with a relative humidity of 80% or less. It should not be stored in the open air.

PIPE CONNECTION

- The flow direction arrow on the valve body must match the direction of flow
- The inlet (up stream) and outlet (downstream) pipes must be in-line and coaxial.
- Pipes should be adequately supported with pipe supports adjacent to the valve.
- When making the joints PTFE tape or a pipe sealing compound should be used to make a gas tight joint.

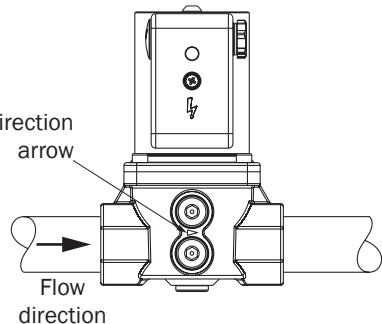

PIPE CONNECTION CONTINUED

- Use a suitably sized spanner or wrench on the flats of the octagonal or hexagonal ends of the valve body when tightening the pipe into the body.
- Do not use any other part of the valve or solenoid to tighten the pipe into the body.

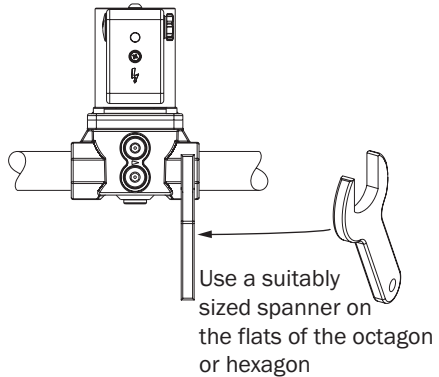

- After making the pipe joints check that they are gas tight.
- Brush a soap solution or use a leakage detection spray around each joint.
- Test the joints with dry air at 2 times the maximum working pressure - see Technical Specification on page 1.
- All joints must be tested individually.
- If bubbles are present it indicates that there is leakage from the joint.
- If there is a leak the joint must re-made and the leakage test repeated.
- The system cannot be used until all joints are proven to be leak tight.

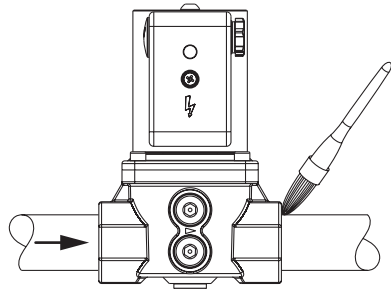

EXISTING INSTALLATION

If installing the gas solenoid valve into an existing system;

- Turn off gas supply before starting installation.
- Disconnect power supply to prevent electrical shock and/or equipment damage.
- Take care to ensure that dirt cannot enter the gas valve during handling and installation.

ELECTRICAL INSTALLATION

- Turn off power supply before making electrical connections or servicing any part of the system.
- Provide a fused isolation switch for the power supply to the actuator.
- Ensure that wiring is in accordance with local regulations.
- Use wire which can withstand 105 °C ambient.
- Follow the instructions supplied by the appliance manufacture.

INSTALLATION

If installing the gas solenoid valve into an existing system;

- Turn off gas supply before starting installation.
- Disconnect power supply to prevent electrical shock and/or equipment damage.
- Take care to ensure that dirt cannot enter the gas valve during handling and installation.

General installation recommendations;

- The GSV gas solenoid valve should be mounted directly in a vertical pipeline or in a horizontal pipeline with the coil uppermost.
- Check that the site conditions comply with the technical specification of the valve.
- The flow direction arrow on the valve body must match the direction of flow.
- Thoroughly purge the pipeline before installing the valve to prevent debris entering the valve and damaging the diaphragm and causing premature failure.
- A gas filter should be installed upstream of the valve to prevent the ingress of debris and prolong the interval between services and the life of the valve.
- **IMPORTANT:** the valve is not explosion proof.
- If installed outdoors or in a harsh environment the valve should be protected accordingly.
- If recommended install a bypass around the gas solenoid valve to aid isolation and future maintenance
- If the valve fails to open or close check that the power supply is connected correctly and turned on. Also check the pressure within the system is within the technical specification of the valve.
- If not installed on the valve, the coil should be stored indoors between 0 to 40 °C with a relative humidity of 80% or less. It should not be stored in the open air.

COIL CARE

The coil can only be powered when attached to the valve. The power must be disconnected if the coil is removed from the valve, failure to do this will result in the coil burning out.

Never energise the coil if not fitted to the valve otherwise this will shorten its life and eventually result in failure.

The coil should be securely fitted to valve, loose fitting will shorten the life of the coil.

Surge/spikes should be prevented from reaching the coil as this will result in failure.

The power supply must be within the tolerance indicated otherwise failure of the capacitor will occur.

The continuous service (100%ED) causes inevitable coil heating.

Depending on working environment the coil surface will be very hot. This situation is absolutely normal.

DECLARATION OF CONFORMITY

According to European Directive 90/396/EEC -73/23/EEC-89/336/EEC.

KIWA EU type examination certificate (GAR) certificate number 19GR0652/00 - meets the essential requirements as described in regulation (EU) 2016/426 relating to appliances burning gaseous fuels, reference standard EN161:2011+A3:2013.

Australia & New Zealand

According to Class 1 AS 4629
IAPMO Certification - GMK10743

