

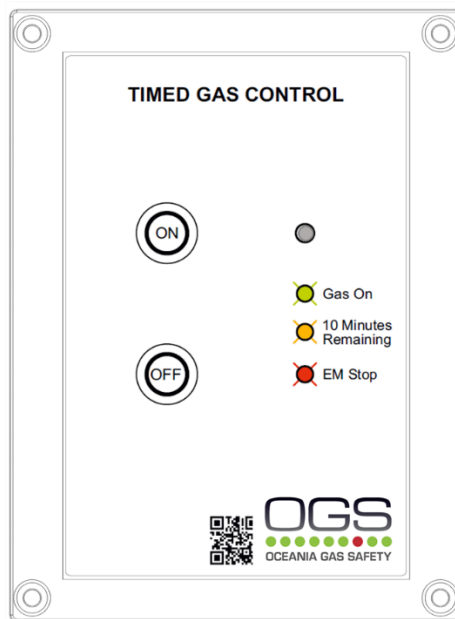

Timed Gas Controller

Model: OGS TGC



Installation, Operation & Maintenance Manual

Please read this manual carefully and retain for future use.

For specific requirements that may deviate from the information in this guide – contact your supplier.

Oceania Gas Safety

www.oceaniagassafety.com

Contents



















Important Warning Statements	3
Installation	4
Typical Application & Location	4
Mounting & Cabling.....	4
Circuit Board Terminals.....	5
Wiring – Power Inputs	5
Wiring – Gas Valve Outputs	6
Wiring – Remote Emergency Stop	6
Selectable Automatic Timeout Switches.....	6
Basic Operation.....	7
Basic Maintenance	7
Specification	8

Important Warning Statements



Warning Symbol!

Where this symbol is used, the manual must be consulted to understand the nature of any potential hazards and how to avoid them.

-  **Before any installation, use or maintenance read this manual carefully.**
 -  **The information contained within this manual should be referenced for typical installation and operation only.**
 -  **For site specific requirements that may deviate from the information in this guide – contact your supplier.**
 -  **If the equipment is used in a manner not specified by the manufacturer, the safety and protection provided by the equipment may be impaired.**
 -  **Installation must be in accordance with recognised standards in the country concerned.**
 -  **When metal conduit is used provision shall be provided by the installer for bonding in accordance with the NFPA70.**
 -  **This product is designed for indoor operation only unless used in conjunction with a weatherproof cover.**
 -  **Cables must be protected against mechanical damage.**
 -  **The internal fuse should be replaced only with the same type. Anti-surge fuse 3.15A 250Vac 5x20.**
 -  **This product is not designed to detect smoke, fire or other gases and should NOT be used as such.**
 -  **This device requires a continual supply of electrical power – it will not work without power.**
 -  **A switch or circuit breaker must be fitted, it must be accessible and marked as the disconnecting device!**
 -  **This device should not be used to substitute proper installation, use and / or maintenance of fuel burning appliances including appropriate ventilation and exhaust systems.**
 -  **Seek fresh air supply and contact your local gas emergency service should you suspect a gas leak.**
 -  **This device may not fully safeguard individuals with specific medical conditions. If in doubt, consult a doctor / physician.**
 -  **Any parts that form part of the connections/installation must have a minimum fire-retardant rating of UL 94V-2!**
 -  **Use with a low-profile surface mount or flush cover available from OGS!**
 -  **Your product should reach you in perfect condition, if you suspect it is damaged, contact your supplier.**
-

Manufacturer's Warranty Statement

Warranty coverage: The manufacturer warrants to the original consumer purchaser, that this product will be free of defects in material and workmanship for a period of twelve months (1 year) from date of purchase.

The manufacturer's liability hereunder is limited to replacement of the product with repaired product at the discretion of the manufacturer. This warranty is void if the product has been damaged by accident, unreasonable use, neglect, tampering or other causes not arising from defects in material or workmanship. This warranty extends to the original consumer purchaser of the product only.

Warranty disclaimers: Any implied warranties arising out of this sale, including but not limited to the implied warranties of description, merchantability and intended operational purpose, are limited in duration to the above warranty period. In no event shall the manufacturer be liable for loss of use of this product or for any indirect, special, incidental, or consequential damages, or costs, or expenses incurred by the consumer or any other user of this product, whether due to a breach of contract, negligence, strict liability in tort or otherwise. The manufacturer shall have no liability for any personal injury, property damage or any special, incidental, contingent or consequential damage of any kind resulting from gas leakage, fire, or explosion. This warranty does not affect your statutory rights.

Warranty Performance: During the above warranty period, your product will be replaced with a comparable product if the defective product is returned together with proof of purchase date. The replacement product will be in warranty for the remainder of the original warranty period or for six months – whichever is the greatest.

Information on waste disposal for consumers of electrical & electronic equipment.



When this product reaches the end of its life it must be treated as Waste Electrical & Electronics Equipment (WEEE).

WEEE marked products must not be mixed with general household waste, but kept separate for the treatment, recovery and recycling of the materials used. Please contact your supplier or local authority for details of recycling schemes in your area.

Installation

Typical Application & Location

⚠ Installation must be in accordance with recognised standards in the country concerned.

The OGS Timed Gas Control unit (TGC) is carefully designed for the commercial and hospitality sector to control the gas supply for a range of appliances such as fireplaces, fire pits and barbeques etc.

The controller incorporates a simple user interface to open/close gas lines and an automatic shutoff timeout feature is configurable via switches upon installation. The controller can also be integrated with remote devices with an open/close circuit isolating the gas supply in an emergency.

Located and installed in positions determined by those who have knowledge of the process plant system and equipment involved, and in consultation with both safety and electrical engineering personnel.

The controller should be installed in the correct orientation, as recommended by the manufacturer at a height to suit public access and status observation (if intended for public use) and is designed for indoor operation unless used in conjunction with a weatherproof cover (sold separately).

Mounting & Cabling

- ⚠ If mounting direct to wall - ensure the wall surface is flat to prevent base distortion!**
- ⚠ Where suitable cable glands/conduits are used for wire entry, use 20mm (3/4 inch) max separated by at least 20mm!**
- ⚠ Fill any holes drilled to maintain integrity of the equipment!**
- ⚠ Any parts that form part of the connections/installation must have a minimum fire-retardant rating of UL 94V-2!**
- ⚠ Restrain the hazardous live wiring from accidental loosening to prevent wires from moving after installation and touching parts of opposite polarity or at low voltages!**
- ⚠ A switch or circuit breaker must be fitted, it must be accessible and marked as the disconnecting device!**
- ⚠ Isolate the equipment from all hazardous live power sources before opening the cover!**
- ⚠ When metal conduit is used provision shall be provided by the installer for bonding in accordance with the NFPA70.**

1. Carefully remove the front cover from the unit by using an M3 socket wrench.
2. Using the rear base - mark mounting holes to the wall or align with an appropriate gang/pattress box.
3. Fixing straight to wall – drill 0.2” (5mm) hole, insert plugs and use the four screws (No.4 Pozi) provided. Alternatively – Fix direct to a vertical 2-gang/double electrical pattress box.
4. There are pre-fractured areas for cable entry on the rear of the base and pilot holes positioned on the top and bottom of the enclosure suitable for entry points up to ¾” (20mm). Drill out as necessary ensuring all swarf is removed from the box and holes have smooth edges.
5. Secure the front cover with all M4 bolts and insert security caps provided.

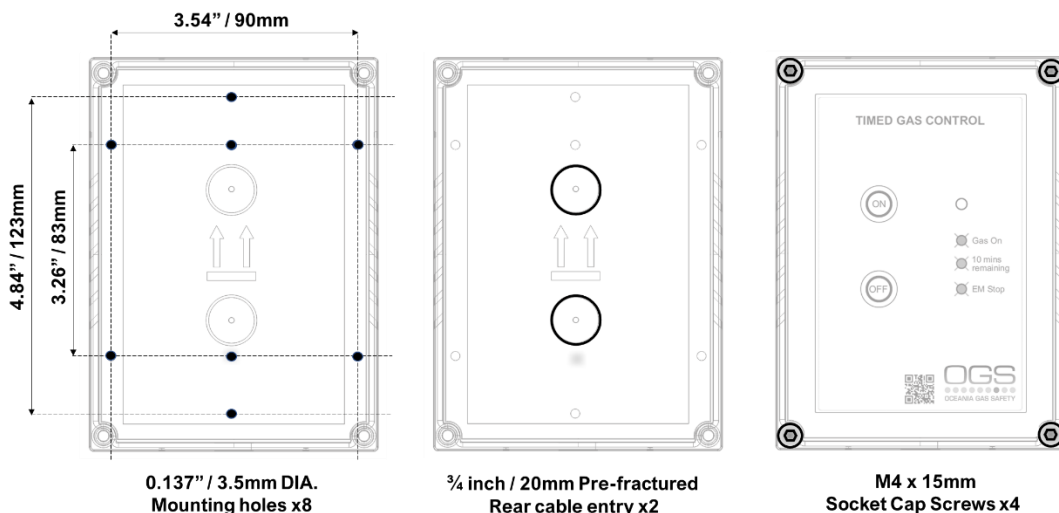

Clear Weatherproof Covers

These indoor/outdoor low-profile covers protect devices without restricting legitimate operation.

The versatile cover offers excellent protection against physical damage (both accidental and intentional), dust and grime as well as severe environmental conditions inside and out.

Wall Mount Cover. Part No: OGS-TGC-WM-COVER
Flush Mount Cover. Part No: OGS-TGC-FM-COVER

Contact your OGS Representative to order.



Circuit Board Terminals

- ⚠ **Damage to PCBs when creating cable entry points may void any warranty!**
- ⚠ **Take care when making connections to high voltage connectors!**
- ⚠ **Any damage attempting to remove the circuit board may void any warranty!**
- ⚠ **All Class 2 wiring is to be installed within flexible tubing to maintain segregation between circuits!**
- ⚠ **Wiring of different circuits shall be separated by means of routing, clamping or barrier!**
- ⚠ **A switch or circuit breaker must be fitted, it must be accessible and marked as the disconnecting device!**
- ⚠ **A disconnecter is required and accessible for the 24V supply and an adequate overcurrent device is fitted!**
- ⚠ **For field connections use wires suitable for at least 167°F (75°C)**
- ⚠ **Any parts that form part of the connections/installation must have a minimum fire-retardant rating of UL 94V-2!**
- ⚠ **Connecting both mains 240V~ and 24Vac/dc power is considered misuse – use only one power input!**
- ⚠ **Terminals are pluggable for ease of wiring and therefore subject to misplacement resulting in a hazardous condition!**

Internal Fuse: Anti-Surge 3.15A 250V~
 Wire Rating Min. 18AWG Tinned Copper @ 167°F / 75°C

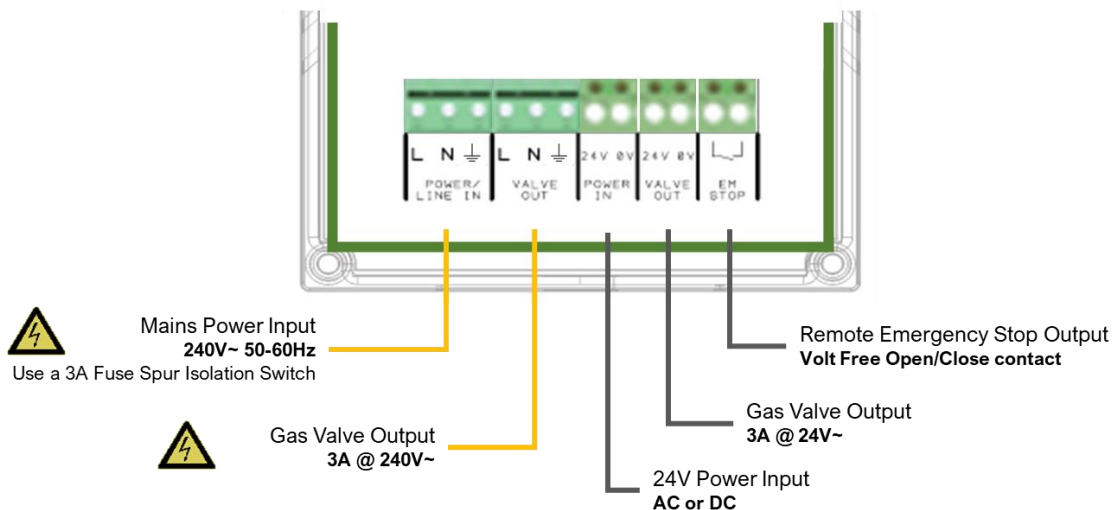

Wiring – Power Inputs

The controller requires a power supply of 100-240V~ Wired to the [POWER/LINE IN] connector using a 3A switched fused spur. Alternatively, the unit can be powered via the 24V [POWER IN] terminal. This can be AC or DC. When power is connected/live, a red LED will illuminate on the front of the controller on the OGS Logo.

Wiring – Gas Valve Outputs

- ⚠ **Use earth terminals for gas valves not considered class II apparatus!**
- ⚠ **Connecting two valves to both mains 240V~ and 24V~ simultaneously is considered misuse – use only one valve output!**

A gas solenoid valve should be powered using one of the terminals marked [VALVE OUT].
Terminals offer control via 100-240V AC or 24V AC.

When wired to a normally closed gas solenoid valve, the TGC controller can be used to isolate the gas supply either by; pressing the Off button on the unit; when the configured time runs out or if remote emergency devices are activated.

Wiring – Remote Stop

- ⚠ **Cable lengths wired to this volt free contact will depend on cable condition and thickness.**

The Timed Gas Controller can be connected to remote devices with an open/close circuit via the [EM STOP] volt free switch terminal.

This terminal has a factory fitted link installed (normally closed circuit) and when open will isolate the gas supply resetting the gas supply timer.

No audible alarm will occur – only the EM Stop LED indicator located on the front fascia will illuminate.

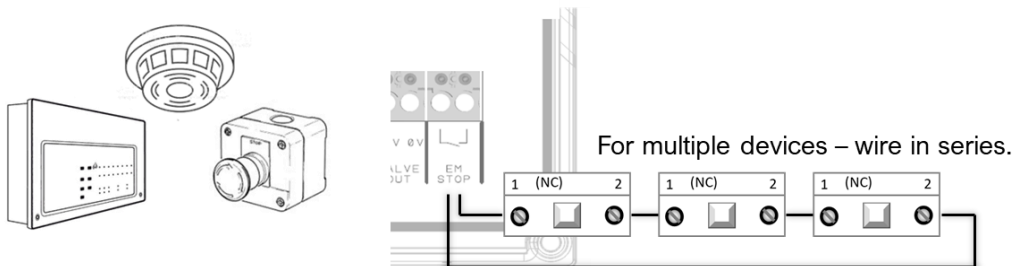

Selectable Automatic Timeout Switches

On the circuit board are two dipswitches used for selecting the automatic gas shut off timeout.

The controller LED will turn yellow ten (10) minutes before the selected time is reached and when five (5) minutes remain the buzzer will beep, and the yellow LED will then intermittently flash.

	S1	S2	Gas Supply Timeout
ON X			
	O	O	= 20 Minutes
	X	O	= 30 Minutes
	O	X	= 60 Minutes
	X	X	= 120 Minutes
OFF O			

After this time, the gas will automatically shut off until reactivated by pressing the 'On' sensor located on the front fascia.

Basic Operation

⚠ Isolate the equipment from all hazardous live power sources before opening the cover!

When power is supplied to the TGC controller, the LED on the logo will illuminate Red. To turn the TGC controller off, disconnect electrical power supply.

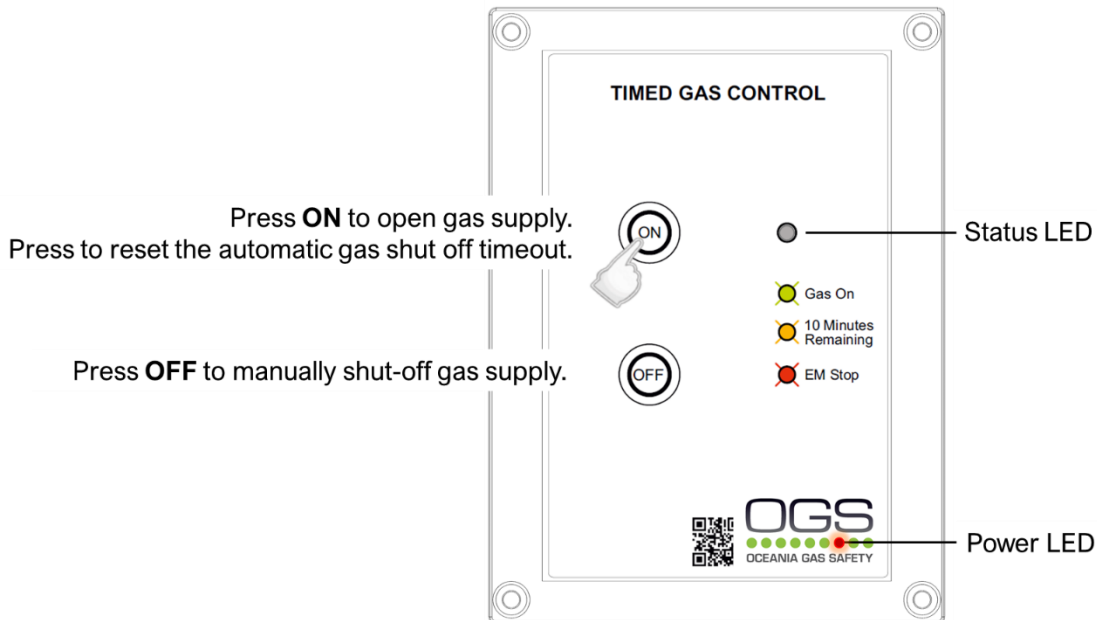

Status LED

The LED changes colour when the controller enters three (3) different states as follows.



Gas On. Remains illuminated when gas is being supplied.



10 Minutes Remaining. The LED will turn yellow ten (10) minutes before the automatic gas shut off timeout is reached and when five (5) minutes remain the buzzer will beep, and the yellow LED will then intermittently flash. After this time, the gas will automatically shut off until reactivated.



EM Stop. Remains illuminated when a remote stop device has been activated.

The gas supply is isolated until the emergency has been investigated, rectified, and reset. Press ON to re-enable/open the gas supply.

Basic Maintenance

⚠ Keep your gas controller in good working order - follow these basic principles.

- ✓ Remove any dust/debris from the outer enclosure regularly using a slightly damp cloth.
- ✓ Never use detergents or solvents to clean your device.
- ✓ Never spray air fresheners, hair spray, paint or other aerosols near the device.
- ✓ Never paint the device.

Specification

General	
Model:	OGS TGC – Timed Gas Controller
Size: (H x W x D)	5.95 x 4.37 x 1.97” (151 x 111 x 50mm)
Housing Material:	ABS PA765 (Flame Rating UL94 V-1)
Mounting:	Wall/Surface Mounted. Indoor use only – Outdoor using weatherproof cover.
Cover (Optional Part)	UV stabilized. 1lb. 5x5x5”
Weight:	11.2 oz (0.32g)
User Interface	
Display:	N/A
Screen Brightness:	N/A
Visual Indicators:	LED. Gas On / Timeout / Emergency Stop
Audible Buzzer:	>60dB @ 3.28ft (1m). Quiet conditions.
Buttons:	Multi-Function – Gas On / Reset Timer / Gas Off
Language:	English
Power Supply	
Power Consumption:	1.2W Max
Power Input #1:	100-240V~ 50-60Hz
Power Input #2	24V AC or DC
Internal Fuse:	Anti-Surge 3.15A @ 250Vac
Equipment	
Overvoltage Category:	II
Pollution Degree:	3 (Unit Only)
Relays	
One	3A @ 110V~
Environmental	
Ingress Protection:	Not formally evaluated. IP4X Determined by inspection.
Operating:	-20 ~ 50°C / 14 ~ 122°F 20 ~ 95% RH (non-condensing)
Storage:	-25 ~ 50°C / -13~122F° up to 95% RH (non-condensing)
Altitude Rating:	2000m
Wiring	
Typical	Min. 18AWG / 75°C min / Tinned copper.
Compliance	
Electrical Safety	CE / UKCA / IEC BS EN 61010-1
Electromagnetic Compatibility	EN 61326-1: 2021 / FCC CFR 47 Parts 15, 107 & 109

Every effort is made to ensure the accuracy of this document; however, OGS can assume no responsibility for any errors or omissions in this document or their consequences. OGS would greatly appreciate being informed of any errors or omissions that may be found in the content of this document. For information not covered in this document, or if there is a requirement to send comments/corrections, please contact OGS using the contact details.

Oceania Gas Safety

www.oceaniagassafety.com

Head office:

Tuakau, Waikato New Zealand

Tel: +64212386990

Email: info@oceaniagassafety.com



Oceania Gas Safety is the owner of this document and reserves all rights of modification without prior notice.